

# 650mT gantry crane



Complete assembled ready for testing

## Application

The object of this hoisting system is to serve in nuclear power plant beyond the regular capacity of the polar crane and handle heat exchangers for replacement. The gantry operates piggyback wise.



Operation in nuclear plant

The nucleus of the gantry crane is the 20' winch and blocks container.

Additional to this container, in length and pitch adjustable legs completed with boogies can be added.

## Technical specifications

Save Working Load	650mT
Traveling length hoist	55m

## System Components

- Containerized winch and top block
- Retractable hoisting block
- Adjustable gantry
- Boogies

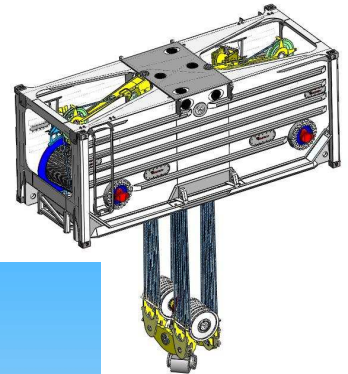

The nucleus;  
20' winch and  
block container

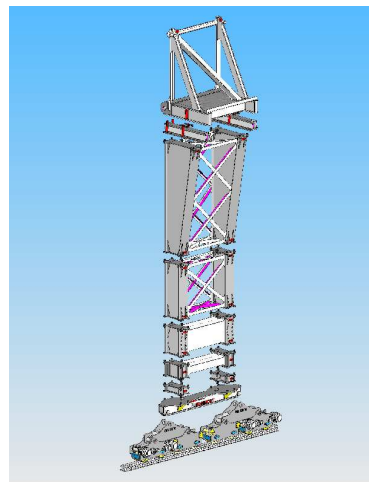

Adjustable leg and boogie

## Features / Innovations

Containerized winch compartment with retractable block and hook construction. Total gantry could be dismantled and transported as 20' container size parts.

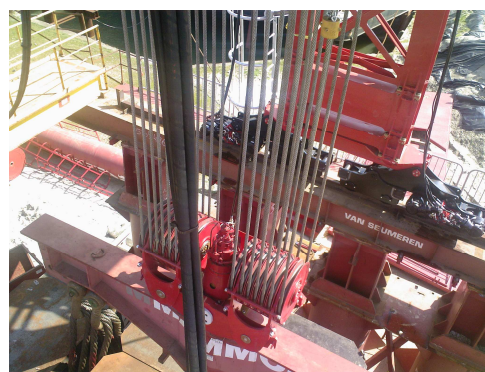

Block and hook